

LAS31

Three-In-One Laser System

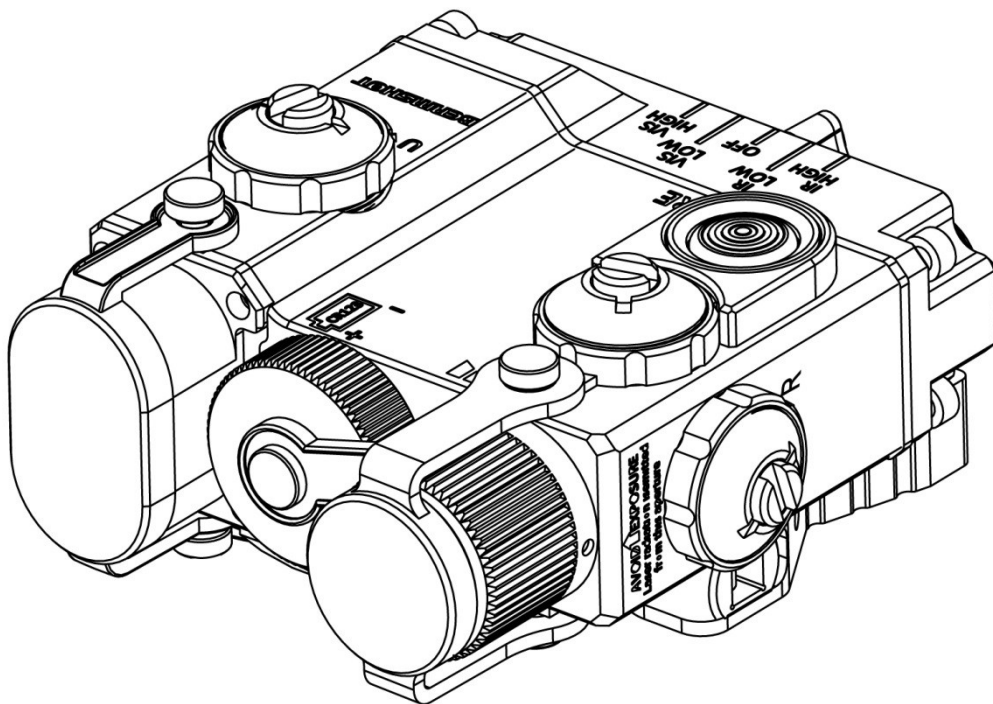

The LAS31 is a 3 in 1 Laser Aiming System that integrates co-aligned visible and IR laser pointers with a focusable IR laser illuminator. All elements are encased in a light weight aerospace aluminum housing that fits onto all small arms equipped with a 1913 picatinny rail.

FEATURES

1. Powerful 70 mW IR Laser Illuminator with focus adjustable beam.
2. Lower power training mode for maximum safety or high power operational mode when in action.
3. Co-aligned visible and IR laser pointer enables single windage/elevation adjustment.
4. Magnetic connected remote switch to avoid damage by high impact force.

SAFETY PRECAUTIONS

DANGER

Table S-1: Nominal Ocular Hazard Distances (NOHD) of **LAS31**.

	Visible Point		IR Point		IR Illuminator	
	Low power mode	High power mode	Low power mode	High power mode	Low power mode	High power mode
Class	Class 3R	Class 3B	Class 1	Class 3B	Class 1	Class 3B
NOHD (Unaided)	39	84	1	118	6	29
NOHD (5-cm aided)	367	680	90	926	57	228
NOHD (8-cm aided)	595	1097	151	1489	93	367
NOHD (12-cm aided)	899	1652	233	2240	141	552
The Minimum Safe Range UNIT : M (Meter)						

Table S-2: Nominal Ocular Hazard Distances (NOHD) of **LAS31-G60**.

	Visible Point		IR Point		IR Illuminator	
	Low power mode	High power mode	Low power mode	High power mode	Low power mode	High power mode
Class	Class 3R	Class 3B	Class 1	Class 3B	Class 1	Class 3B
NOHD (Unaided)	34	197	1	118	6	29
NOHD (5-cm aided)	380	1539	90	926	57	228
NOHD (8-cm aided)	622	2476	151	1489	93	367
NOHD (12-cm aided)	945	3724	233	2240	141	552
The Minimum Safe Range UNIT : M (Meter)						

Table S-3: Nominal Ocular Hazard Distances (**NOHD**) of **LAS31-G60-IR940**.

	Visible Point		IR Point		IR Illuminator	
	Low power mode	High power mode	Low power mode	High power mode	Low power mode	High power mode
Class	Class 3R	Class 3B	Class 1	Class 3B	Class 1	Class 3B
NOHD (Unaided)	34	197	0.45	126.05	1	1
NOHD (5-cm aided)	380	1539	95.36	992.48	1.5	3.9
NOHD (8-cm aided)	622	2476	161.58	1596.97	2.4	6.3
NOHD (12-cm aided)	945	3724	249.87	2402.96	3.7	9.5
The Minimum Safe Range UNIT : M (Meter)						

Exposure to the laser beam inside the NOHD minimum safe range can cause permanent damage to the human eye.

DANGER

- **CLASS 3B LASER PRODUCT.**
(Infrared & Visible Laser Point at high power mode and Infrared Laser Illuminator at high power mode)
- Laser radiation when open. **AVOID DIRECT EXPOSURE TO BEAM.**

DANGER

- **CLASS 3R LASER PRODUCT.**
(Visible Laser Point at low power mode)
- Laser radiation when open. **AVOID DIRECT EYE EXPOSURE.**

LASER SAFETY WARNING

DANGER

- Use of controls or adjustments, or performance of procedures other than those specified herein may result in hazardous radiation exposure.
- This laser product is classified as Class 3R & Class 3B for Visible point and Class 3B & Class 1 for IR point/illuminator according to 21 CFR 1040.
- Avoid all eye contact .Never look directly into the laser lens even if the laser is off.
- Do not stare into the laser beams and laser aperture.
- Do not look into the laser beam through binoculars or telescopes.
- Do not point the laser beam at reflective surfaces.
- Never aim the laser beam at people's eyes.
- This unit must be used by experienced technical personnel only.
- Do not leave the laser beam unattended.
- Do not target vehicles or aircraft with the laser beam when the unit is used outdoors.
- Do not look directly into laser beam with optical instrumentation unless adequate protective filters are used to protect the eyes.
- Avoid aiming the laser beam at mirror- likes surfaces. Remove any unnecessary mirror-likes surface from the vicinity of the laser beam path.
- The warranty will no longer exist once the product been taken apart.

CAUTION

- Use of controls or adjustments, or performance of procedures other than those specified herein may result in hazardous radiation exposure.
- When not in use, always keep the Power selector knob on Power OFF position, Including when in storage.
- When not in use, always close all of the Rubber Safety Covers, Including when in storage.
- **Battery** : The **LAS31** is powered by **CR123A Lithium battery**.
- Do not allow water to enter the housing by keeping the battery cap shut.
- Do not store the **LAS31** with battery installed.
- Do not attempt to recharge.
- Do not install a defective battery in the **LAS31**.
- Prior to operating, check to see all batteries for cracks, bulging, and leakage.
- Do not puncture, disassemble, short circuit.

TABLE OF CONTENTS

FEATURES	2
SAFETY PRECAUTIONS	3
TABLE OF CONTENTS	8
CHAPTER 1 : CONTENTS OF A SET	9
CHAPTER 2 : SPECIFICATIONS	10
CHAPTER 3 : CONSTRUCTION	15
CHAPTER 4 : OPERATING PROCEDURES	17
4.1 Battery Installation	17
4.2 Power Mode Selection	18
4.3 LED Indicator	19
4.4 Power & Laser Activation	20
4.5 Mounting	25
4.6 Zeroing in	26
CHAPTER 5 : BASIC MAINTENANCE	33

CHAPTER 1

CONTENTS OF A SET

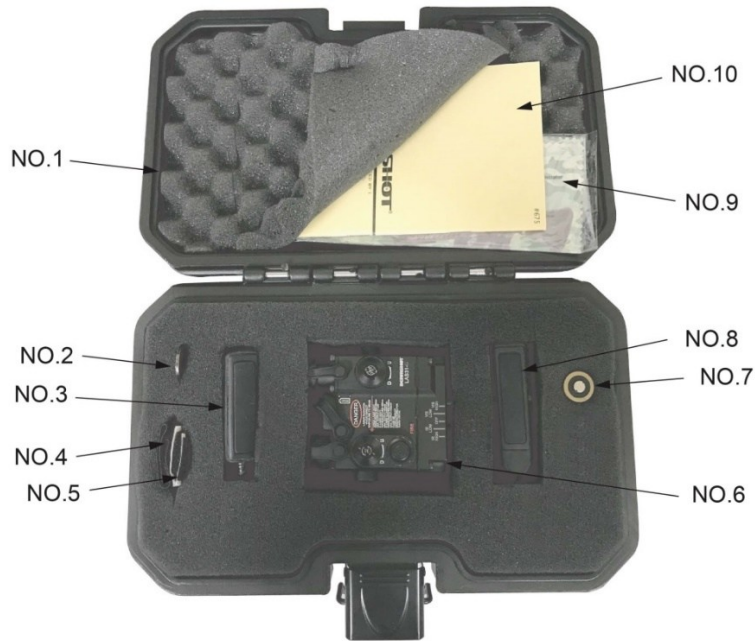

Fig. 1-1

TABLE1-1

No.	Part Name	Parts Stock Number(PSN)
1	Hard Covered Carrying Case	492-5B101G
2	Alignment Plate	426-5BF01G-3
3	MPSV-10 10 inches long Magnetic connection Pressure pad Switch with Velcro attached	264-5B112G
4	Polyester elastic band	467-07005G
5	Velcro Pad	467-07001G
6	LAS31 3 in 1 Laser Aiming	257-BQ001G(LAS31-G)/ 257-BQ002G(LAS31-R)/ 257-BQ005G(LAS31-G60)/ 257-BQ006G(LAS31-G60-IR940)
7	CR123A Battery	451-C0103G
8	MPSR-10 10 inches long Magnetic connection Pressure pad Switch	264-5B111G
9	Lens cloth	499-5B110G
10	User Manual	494-50705G

CHAPTER 2 SPECIFICATIONS

LAS31-G TABLE 2-1(a)

Mechanical Characteristics	
Weight (with battery)	215±10 g
Dimensions	85(L) x 76(W) x 43(H) mm
Mount	MIL-STD-1913 rail / NATO 1913
Water Resistance	MIL-STD-810G
Laser Wavelength	
Visible Laser Sight	510~530 nm(Green Laser)
Infrared Laser Sight / Illuminator	820~860 nm
Output Power(High/Low)	
Visible Laser Sight	4±1mW (Low) / 15±5mW (High)
Infrared Laser Sight	<0.7mW (Low)(Class 1) / 45±5mW (High)
Infrared Laser Illuminator	4±1mW (Low) / 70±20mW (High)
Beam Divergence	
Visible Laser Sight	<0.5 mRad
	(0.5~1 mRad Full angle)
Infrared Laser Sight	<0.5 mRad
	(0.5~1 mRad Full angle)
Infrared Laser Illuminator	1 to 105 mRad (0.06° to 6°)
Sight Range (Night Time / Day Time)	
Visible Laser Sight	High(5000m/50m), Low(2000m/20m)
Infrared Laser Sight	High(5000m) , Low(600m)
Infrared Laser Illuminator	High(5000m) , Low(600m)
Bore sighting & Alignment	
Movement per Click	2.5 MOA / 0.727 mRad / 0.04167°, 2.62" @ 100 yards (7.3cm @ 100 meters)
Movement from center	60±10 MOA(1°±0.16°)
Total Travel	120±20 MOA(2°±0.32°)
Operating Temperature	
Laser Point / Illuminator	-40°C ~ +65°C (-40°F ~ 149°F)
Operating Time (Hours)	
Visible Laser Point	5+ hrs(Green)
Infrared Laser Point	10+ hrs
Infrared Laser Illuminator	8+ hrs

SPECIFICATIONS

LAS31-R TABLE 2-1(b)

Mechanical Characteristics	
Weight	215±10 g
Dimensions	85(L) x 76(W) x 43(H) mm
Mount	MIL-STD-1913 rail / NATO 1913
Water Resistance	MIL-STD-810G
Laser Wavelength	
Visible Laser Sight	620~680 nm(Red Laser)
Infrared Laser Sight	820~860 nm
Infrared Laser Illuminator	820~860 nm
Output Power(High/Low)	
Visible Laser Sight	4±1mW (Low) / 15±5mW (High)
Infrared Laser Sight	<0.7mW (Low)(Class 1) / 45±5mW (High)
Infrared Laser Illuminator	4±1mW (Low) / 70±20mW (High)
Beam Divergence	
Visible Laser Sight	<0.5 mRad
	(0.5~1 mRad Full angle)
Infrared Laser Sight	<0.5 mRad
	(0.5~1 mRad Full angle)
Infrared Laser Illuminator	1 to 105 mRad (0.06° to 6°)
Sight Range (Night Time / Day Time)	
Visible Laser Sight	High(2000m/30m), Low(500m/10m)
Infrared Laser Sight	High(5000m) , Low(600m)
Infrared Laser Illuminator	High(5000m) , Low(600m)
Bore sighting & Alignment	
Movement per Click	2.5 MOA / 0.727 mRad / 0.04167°, 2.62" @ 100 yards (7.3cm @ 100 meters)
Movement from center	60±10 MOA(1°±0.16°)
Total Travel	120±20 MOA(2°±0.32°)
Operating Temperature	
Laser Point / Illuminator	-40°C ~ +65°C (-40°F ~ 149°F)
Operating Time (Hours)	
Visible Laser Point	10+ hrs(Red)
Infrared Laser Point	10+ hrs
Infrared Laser Illuminator	8+ hrs

SPECIFICATIONS

LAS31-G60 TABLE 2-1(c)

Mechanical Characteristics	
Weight	215±10 g
Dimensions	85(L) x 76(W) x 43(H) mm
Mount	MIL-STD-1913 rail / NATO 1913
Water Resistance	MIL-STD-810G
Laser Wavelength	
Visible Laser Sight	510~530 nm(Green Laser)
Infrared Laser Sight	820~860 nm
Infrared Laser Illuminator	820~860 nm
Output Power(High/Low)	
Visible Laser Sight	4±1mW (Low) / 60±5mW (High)
Infrared Laser Sight	<0.7mW (Low)(Class 1) / 45±5mW (High)
Infrared Laser Illuminator	4±1mW (Low) / 70±20mW (High)
Beam Divergence	
Visible Laser Sight	<0.5 mRad
	(0.5~1 mRad Full angle)
Infrared Laser Sight	<0.5 mRad
	(0.5~1 mRad Full angle)
Infrared Laser Illuminator	1 to 105 mRad (0.06° to 6°)
Sight Range (Night Time / Day Time)	
Visible Laser Sight	High(5000m/50m), Low(2000m/20m)
Infrared Laser Sight	High(5000m) , Low(600m)
Infrared Laser Illuminator	High(5000m) , Low(600m)
Bore sighting & Alignment	
Movement per Click	2.5 MOA / 0.727 mRad / 0.04167°, 2.62" @ 100 yards (7.3cm @ 100 meters)
Movement from center	60±10 MOA(1°±0.16°)
Total Travel	120±20 MOA(2°±0.32°)
Operating Temperature	
Laser Point / Illuminator	-40°C ~ +65°C (-40°F ~ 149°F)
Operating Time (Hours)	
Visible Laser Point	2 hrs(Green)
Infrared Laser Point	10+ hrs
Infrared Laser Illuminator	8+ hrs

SPECIFICATIONS

LAS31-G60-IR940 TABLE 2-1(d)

Mechanical Characteristics	
Weight	215±10 g
Dimensions	85(L) x 76(W) x 43(H) mm
Mount	MIL-STD-1913 rail / NATO 1913
Water Resistance	MIL-STD-810G
Laser Wavelength	
Visible Laser Sight	510~530 nm(Green Laser)
Infrared Laser Sight	920~960 nm
Infrared Laser Illuminator	920~960 nm
Output Power(High/Low)	
Visible Laser Sight	4±1mW (Low) / 60±5mW (High)
Infrared Laser Sight	<0.7mW (Low)(Class 1) / 45±5mW (High)
Infrared Laser Illuminator	4±1mW (Low) / 70±20mW (High)
Beam Divergence	
Visible Laser Sight	<0.5 mRad
	(0.5~1 mRad Full angle)
Infrared Laser Sight	<0.5 mRad
	(0.5~1 mRad Full angle)
Infrared Laser Illuminator	1 to 105 mRad (0.06° to 6°)
Sight Range (Night Time / Day Time)	
Visible Laser Sight	High(5000m/50m), Low(2000m/20m)
Infrared Laser Sight	High(5000m) , Low(600m)
Infrared Laser Illuminator	High(5000m) , Low(600m)
Bore sighting & Alignment	
Movement per Click	2.5 MOA / 0.727 mRad / 0.04167°, 2.62" @ 100 yards (7.3cm @ 100 meters)
Movement from center	60±10 MOA(1°±0.16°)
Total Travel	120±20 MOA(2°±0.32°)
Operating Temperature	
Laser Point / Illuminator	-40°C ~ +65°C (-40°F ~ 149°F)
Operating Time (Hours)	
Visible Laser Point	2 hrs(Green)
Infrared Laser Point	10+ hrs
Infrared Laser Illuminator	8+ hrs

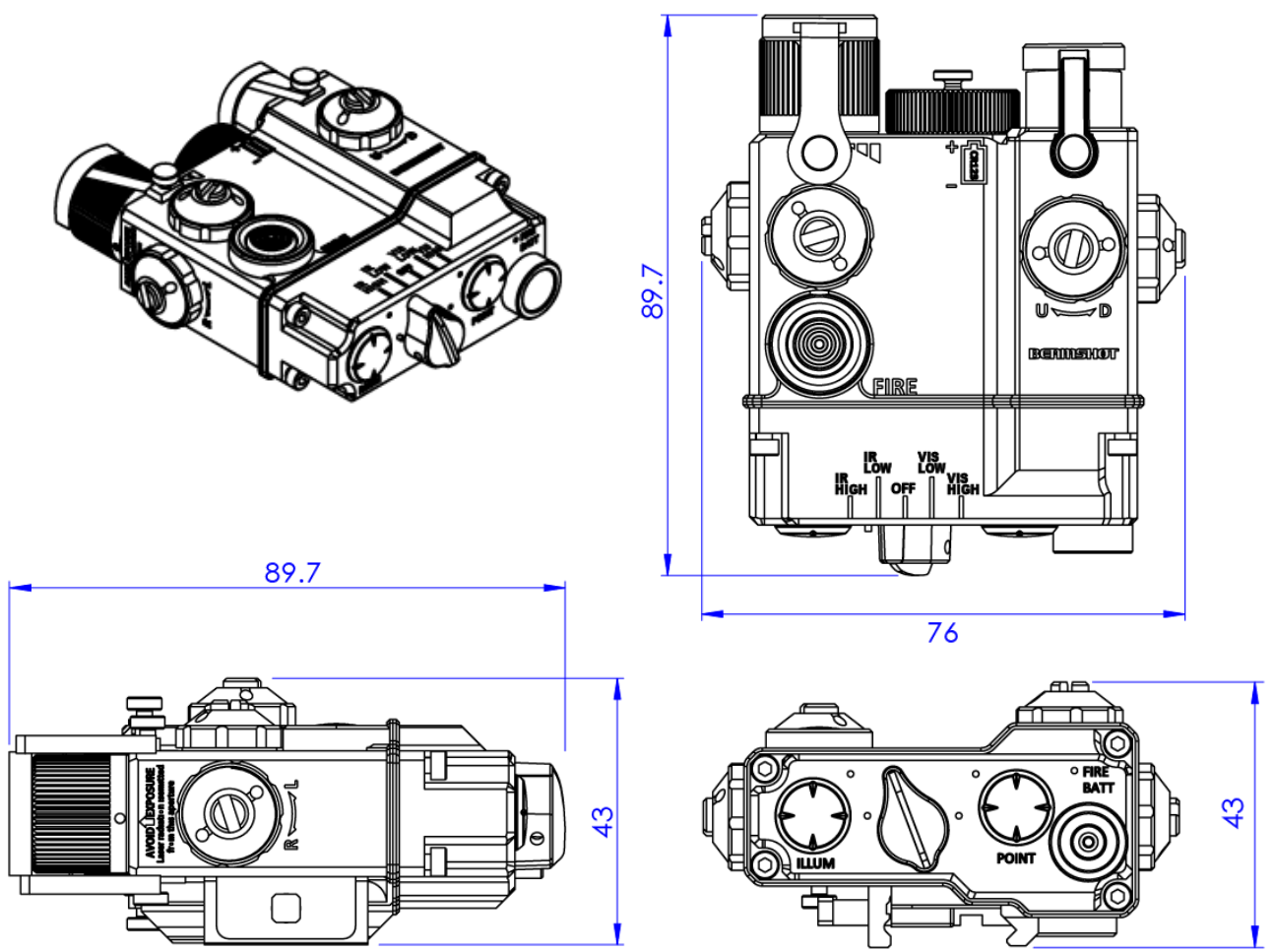
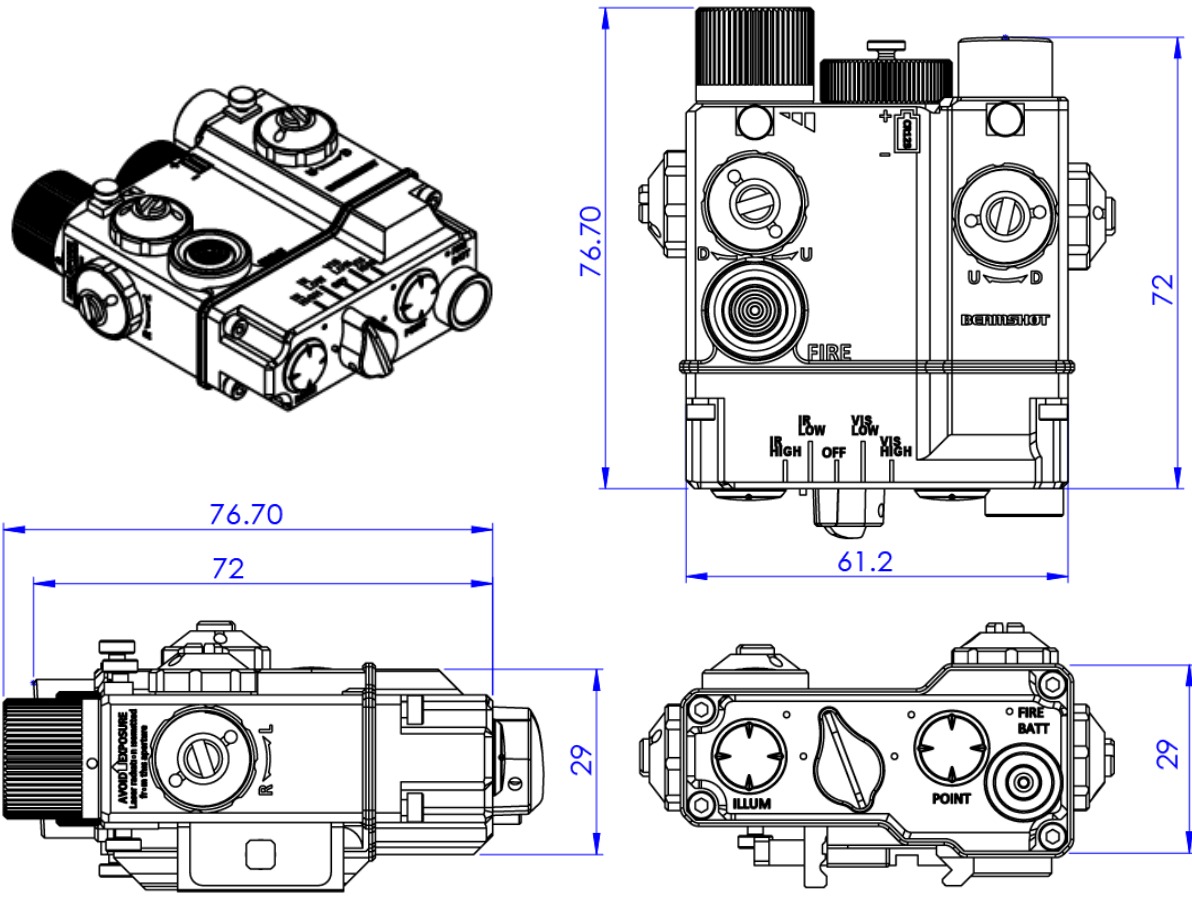

CHAPTER 3

CONSTRUCTION

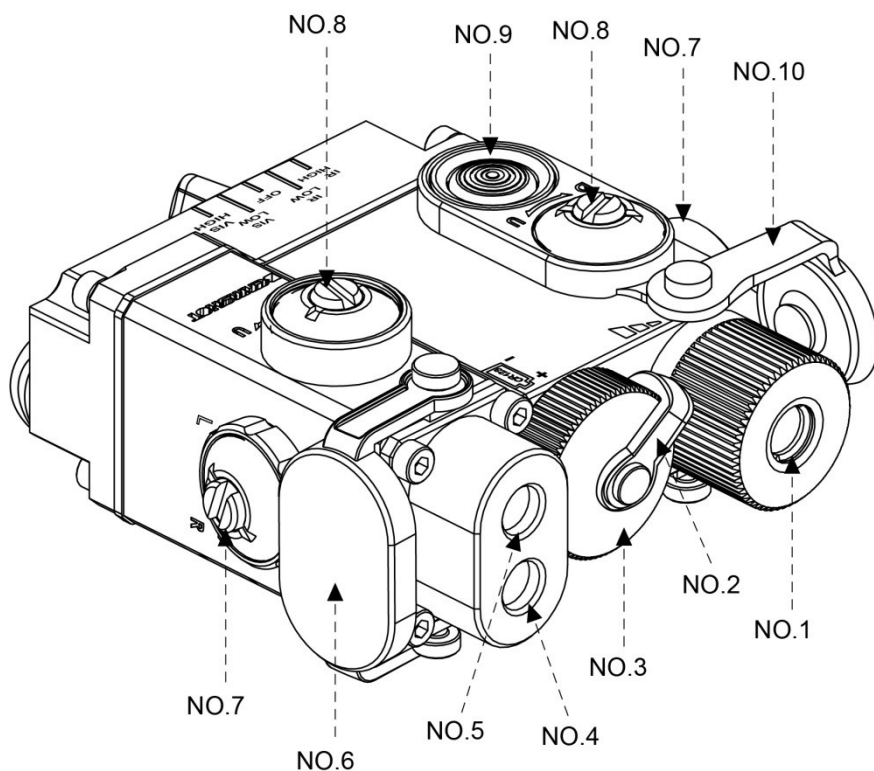

LAS31 TABLE 3-1(a)

No.	Description
1	IR Laser Illuminator Aperture
2	Battery Cap Rubber Strap
3	Battery Cap
4	Visible Laser Point Aperture
5	IR Laser Point Aperture
6	Laser Point Safety Cover
7	Windage Adjuster
8	Elevation Adjuster
9	Laser Fire Button
10	IR Laser Illuminator Safety Cover

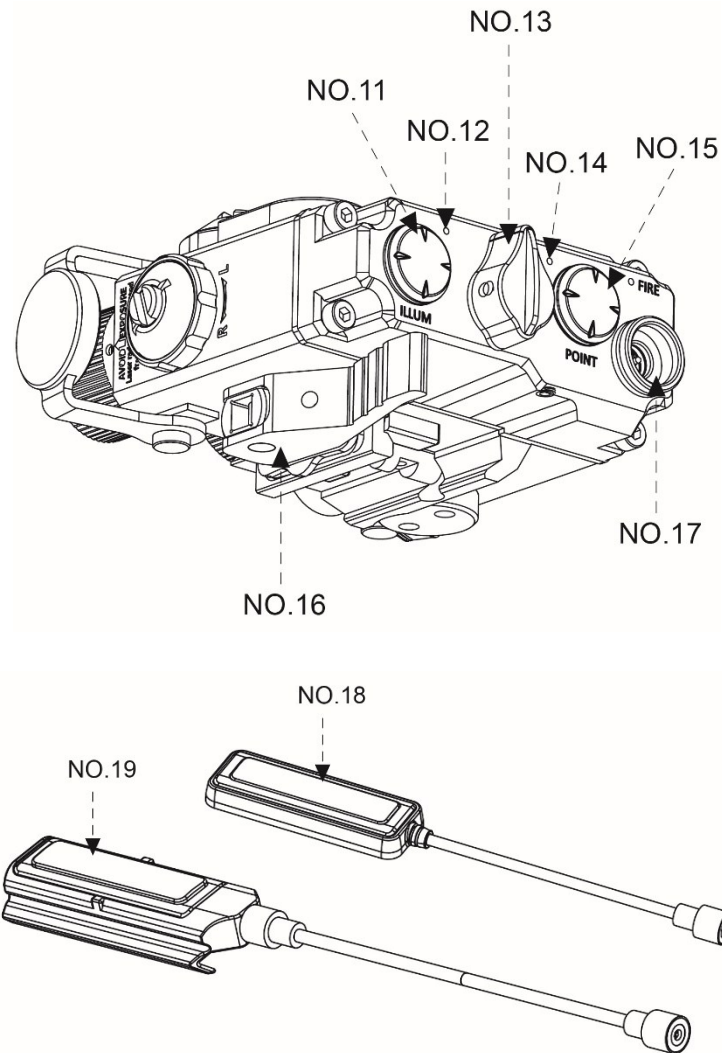

LAS31 TABLE 3-1(b)

No.	Description
11	IR Laser Illuminator Button
12	IR Laser Illuminator Indicator
13	Power selector knob
14	Visible & IR Laser Point Indicator
15	Visible & IR Laser Point Button
16	Quick-release Mount Clamp
17	Pressure Pad Switch Connector
18	MPSV-10 10 inches Long Magnetic Connector Pressure Pad Switch With Velcro Pad
19	MPSR-10 10 inches Long Magnetic Connector Pressure Pad Switch Rail Type

CHAPTER 4

OPERATING PROCEDURES

4.1 Battery Installation

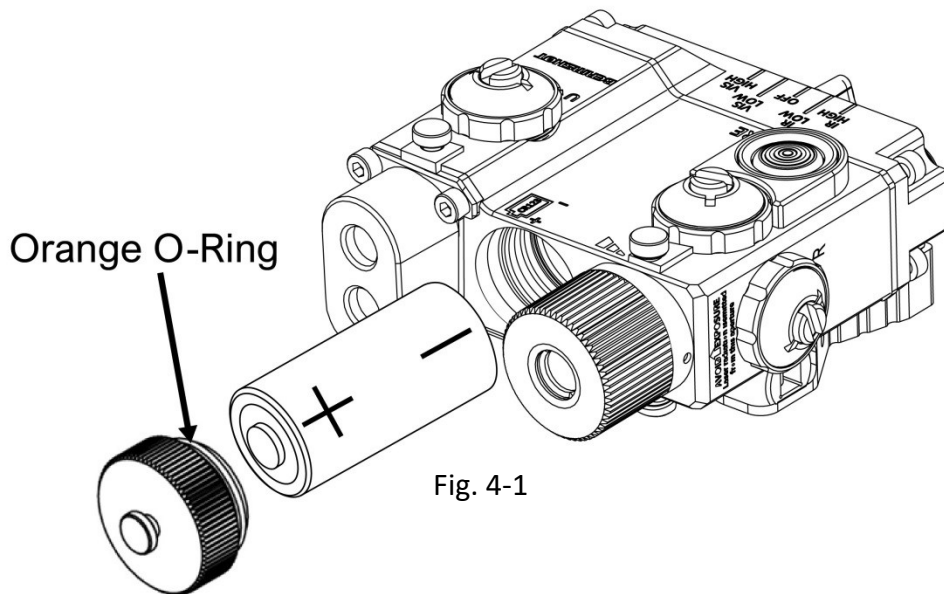

Unscrew battery cap, insert **CR123A** battery. Positive pole points toward outside as in Fig. 4-1. **Tightly screw battery cap.**

We suggest use **Panasonic CR123A Lithium** batteries for optimal battery life.

Power Supply:

One CR123A Battery (3.0 Volt)

Note

- Battery life is reduced when using rechargeable CR123A and Alkaline batteries CR123A.
- Do not store the LAS31 with battery installed.
- **Please make sure fasten battery cap till orange O-Ring can't be visible to avoid water seep into LAS31.**

4.2 Power Mode Selection

Power mode is showing in follow Fig. 4-2:

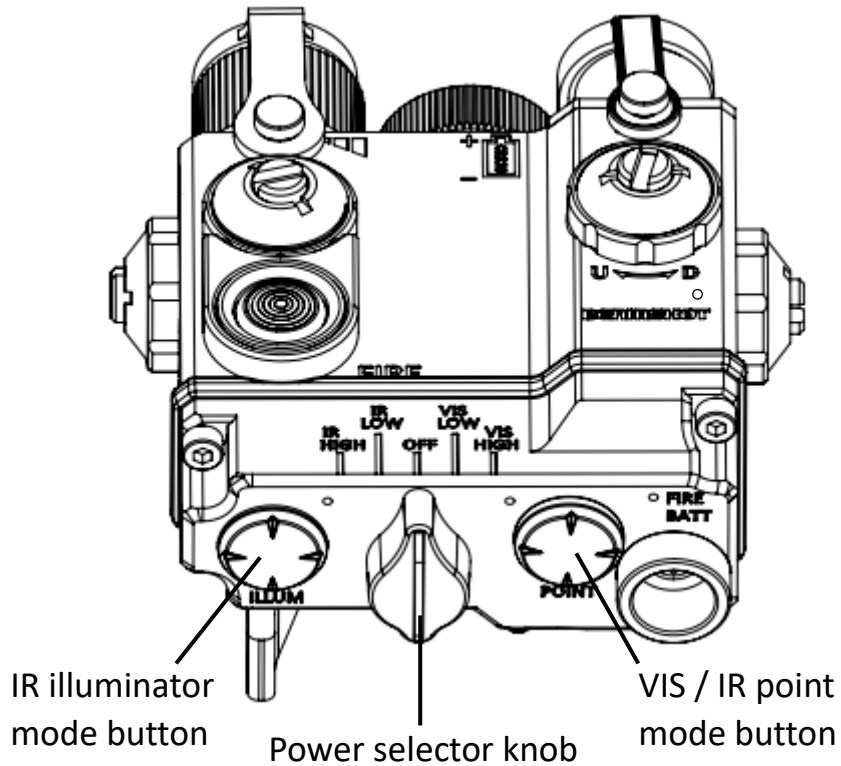

Fig 4-2

Table 4-2 Power Switch Selection:

Position	Status
OFF	System power off
VIS LOW	Visible Point Low Power Mode
VIS HIGH	Visible Point High Power Mode
IR LOW	IR Point/Illuminator Low Power Mode
IR HIGH	IR Point/Illuminator High Power Mode

Note: Always move the power selector knob to “OFF” after use.

4.3 LED Indicator

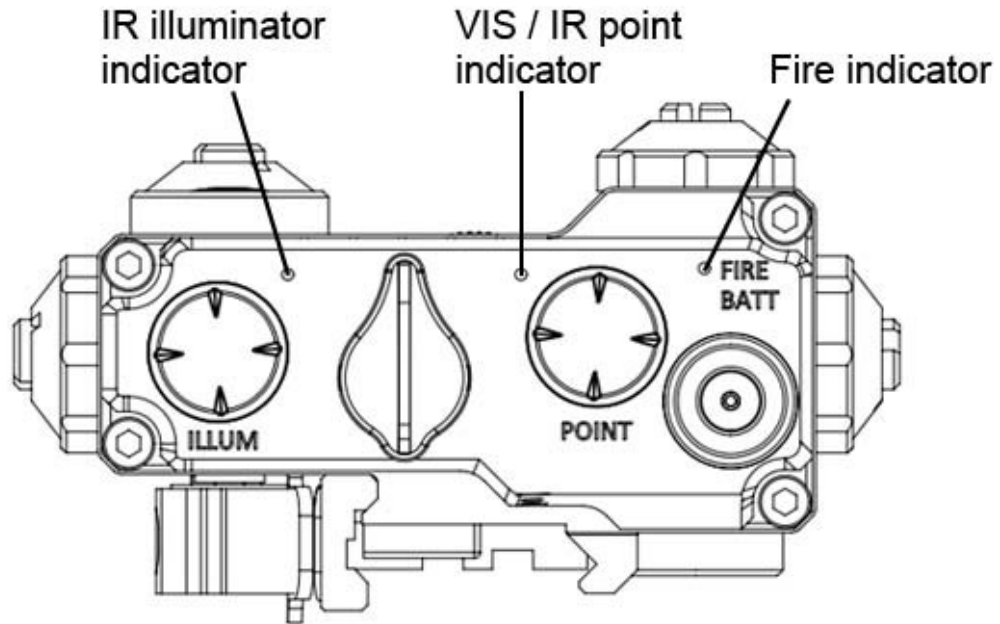

Fig. 4-3

Table 4-3 Dual LED Indicator Color Status:

LED Indicator	LED Color	Status
VIS/IR POINT Indicator	Red	High power mode ready
	Green	Low power mode ready
	Strobe	Strobe mode ready
IR ILLUMINATOR Indicator	Red	High power mode ready
	Green	Low power mode ready
	Strobe	Strobe mode ready
Fire Indicator	Green	Laser is Emitting
	Red	Laser is emitting and low battery indication

4.4 Power & Laser Activation

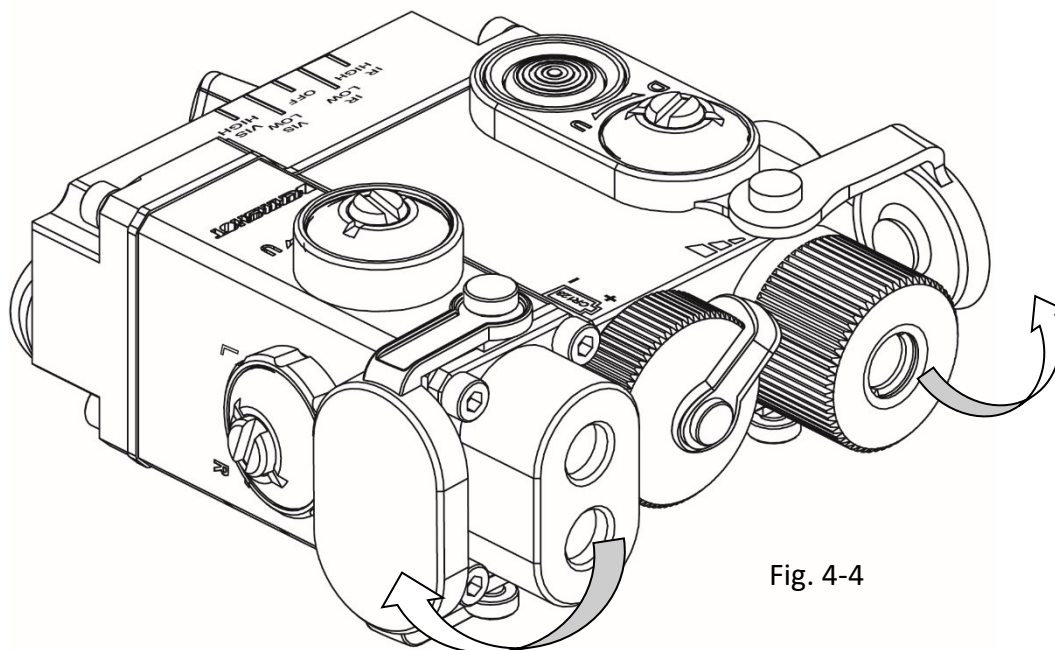

Fig. 4-4

1. Select power mode by Power selector knob.
2. Open the Rubber Safety Cover (In Fig. 4-4, is show Open).
3. All three function: Visible Laser Point, IR Laser Point and IR Illuminator work independently and IR Laser Point & IR Illuminator can be turned on to operate at the same time.
4. Turn the power selector knob to the VIS HIGH/VIS LOW/IR LOW/IR HIGH , press the POINT/ILLUM mode button once, the corresponding indictors will go on and Visible Laser Point/IR Point/IR Illuminator will be on whenever Fire Button and Pressure pad switch is compressed. Press the POINT/ILLUM mode button again, the corresponding indictors will strobe and Visible Laser Point/IR Laser Point/IR Illuminator will strobe whenever Fire Button and Pressure pad switch is compressed. Press the POINT/ILLUM mode button again, the corresponding indictors will be off and Visible Laser Point/IR Laser Point/IR Illuminator can't be turned on. Press the POINT/ILLUM mode button again, the corresponding indictors will go on and Visible Laser Point/IR Laser Point/IR Illuminator will be on whenever Fire Button and Pressure pad switch is compressed.

5. Press Laser Fire button (rubber covered button on top of the unit) or Pressure pad switch, laser will fire.
6. Quick Press Laser Fire button (rubber covered button on top of the unit) or Pressure pad switch TWICE, laser will be in constant on mode.(for safety reason, Laser will auto shutdown after 5 minutes).
7. Please note: always turn Power selector knob to "OFF" position after use.
8. Please note: Always close the Rubber Safety Cover after use.

MPSR-10 Magnetic Pressure Pad Switch Rail Type Install Procedures

Lock procedure (As shown in Fig 4-4.1, Fig4-4.2, Fig4-4.3, Fig 4-4.4, Fig4-4.5)



Fig. 4-4.1



Fig. 4-4.2
Alignment Picatinny Rail

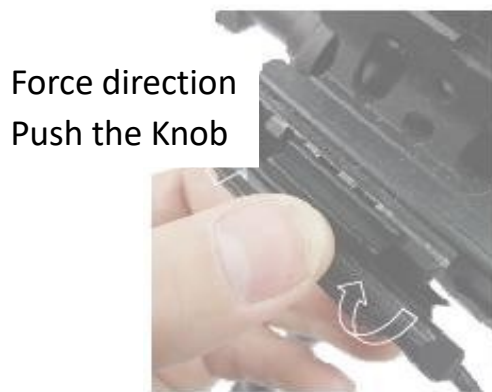

Fig. 4-4.3



Fig. 4-4.4

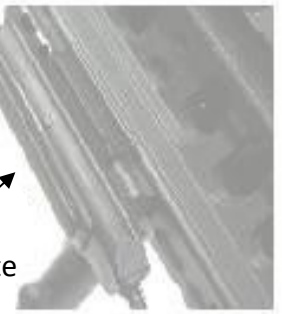

Fig. 4-4.5

Unlock procedure (As shown in Fig 4-4.6)



Force direction

Fig 4-4.6

MPSV-10 Remote Pressure Pad Switch Cable Velcro Type Install Procedures

Lock procedure (As shown in Fig 4-4.7, Fig4-4.8, Fig4-4.9, Fig 4-4.10, Fig4-4.11)

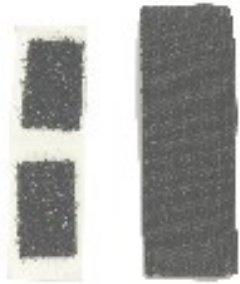

Fig.4-4.7



Fig.4-4.8

Left: Velcro pad with sticky back.

Right: Polyester elastic band with Velcro stitching.



Fig.4-4.9



Fig.4-4.10



Fig.4-4.11

Use Velcro Pad

1. Stick Velcro pad on convenient place for switch operation as Fig 4-4.8
2. Place Switch onto Velcro pad as Fig 4-4.9/ Fig 4-4.10

Use Polyester elastic band

1. Place polyester elastic band on grip
2. Place Switch onto Velcro on the band as Fig .4-4.11

4.5 Mounting

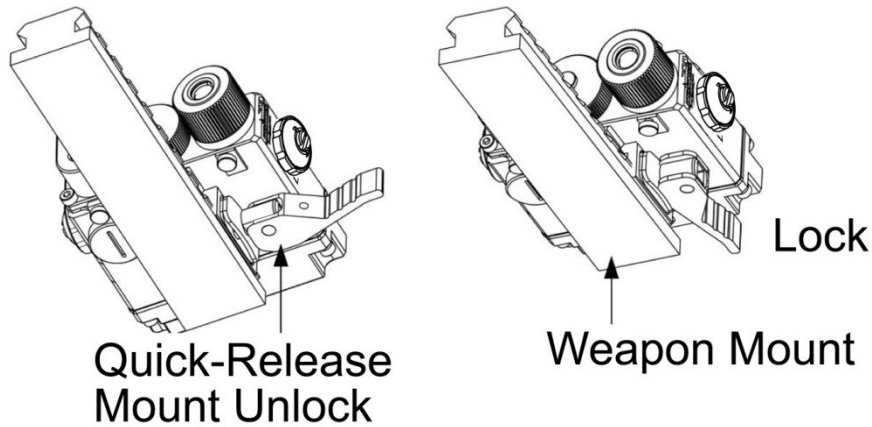
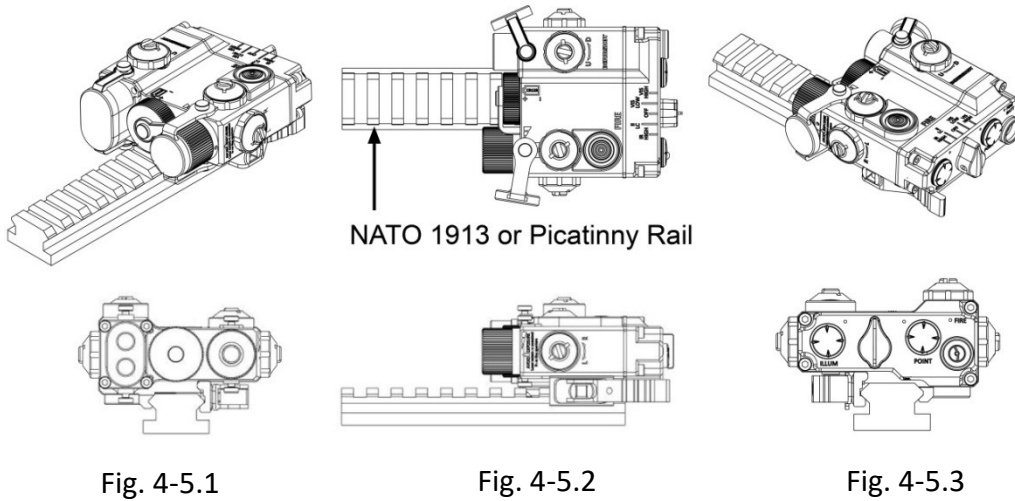

Using the integrated rail mounting system, the LAS31 can attach to a Picatinny rail (either vertically or horizontally depending on rail access). As shown in Fig. 4-5.1, 4-5.2, 4-5.3

NOTE

We guarantee the quality of workmanship of this product. Prior to shipping from our factory, stringent quality control measures of varying intensity are employed. Minor scratches on the mount may be evident, but is considered normal.

Test References: MIL-STD-901D, MIL-STD-810G

4.6 Zeroing in

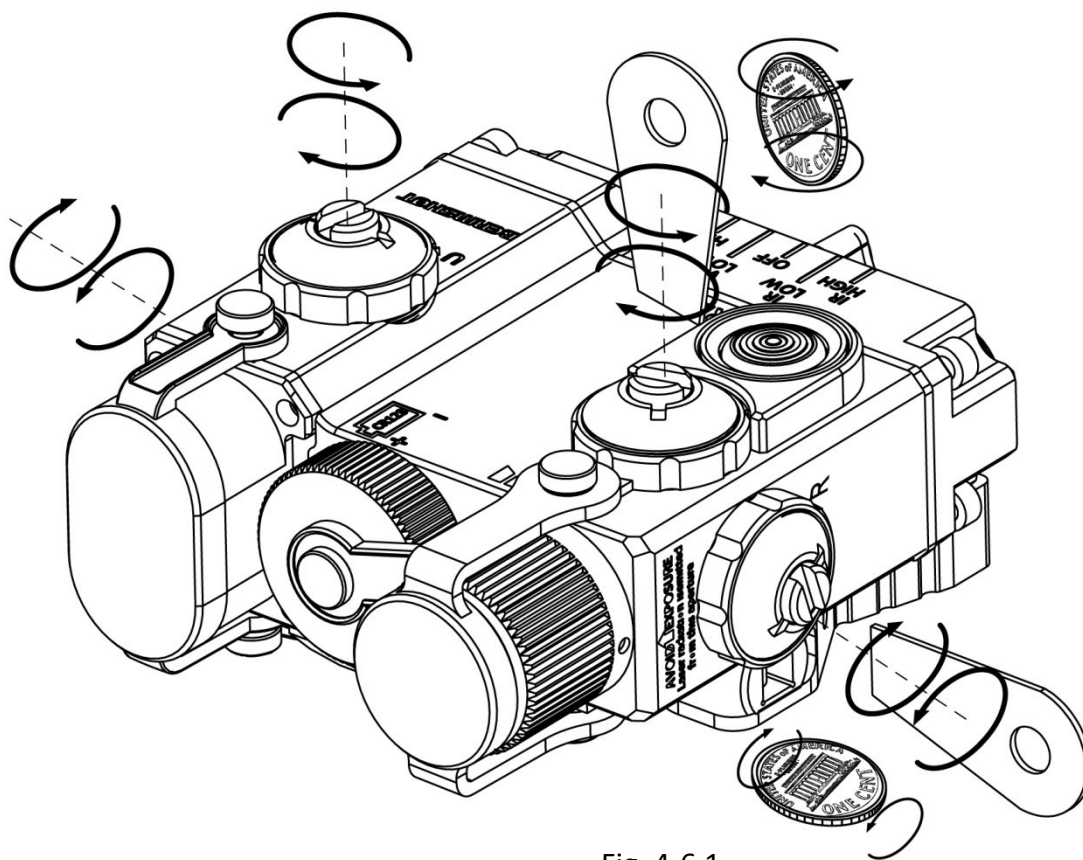
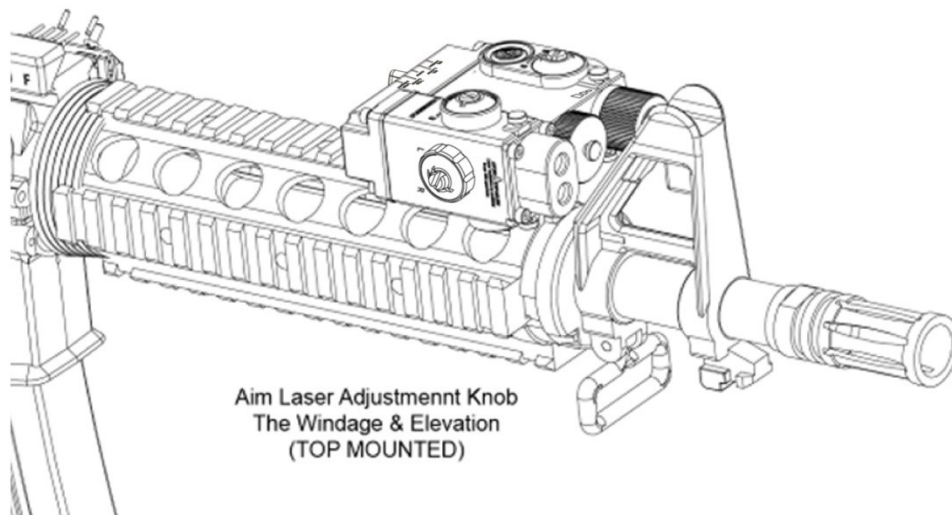
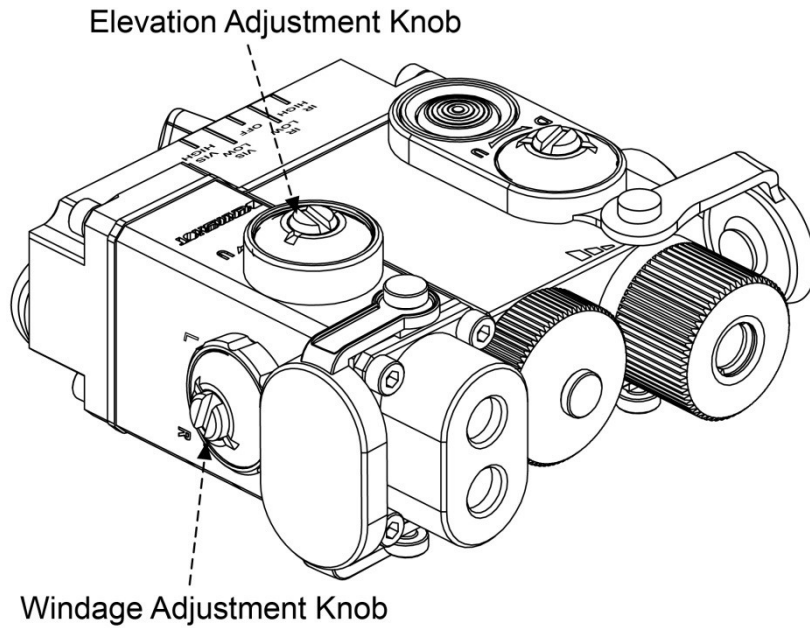

Fig. 4-6.1

- Turn the windage and elevation adjustments to align the laser point to your iron sight as shown in Fig. 4-6.1
- Each click of the adjustment knob will move the laser point by 0.8 inch at 100 yards (2.3cm at 100 meters) . **The Infrared Laser Illuminator** can be focused (**2~100 mRad**) by using the Zoom Wheel.
- To ensure your LAS31 Laser System is zeroed on your bullet trajectory at a certain distance, test at the shooting range.
- Ensure both the IR and Visible laser points co-align with the iron sight & bullet impact.
- When you are adjusting the IR & Visible laser point, the windage & elevation will adjust them together. They do not have independent adjustments as they are co-aligned.
- Do not over torque the adjustment knobs beyond the stop. Caution must be taken to only adjust them "**finger-tight**".

Windage & Elevation Adjustment Knobs



Shot Group Movement for Laser point (Top Mounted)

TABLE 4-6

Adjuster	Rotation	Laser Direction
Top Adjustment Knob Elevation	CW. CCW	Up / Down
Side Adjustment Knob Windage	CW. CCW	Right / Left

NOTE

Do not over torque the adjustment knobs beyond the stop.
Caution must be taken to only adjust them "**finger-tight**".

Windage & Elevation Adjustment Knobs

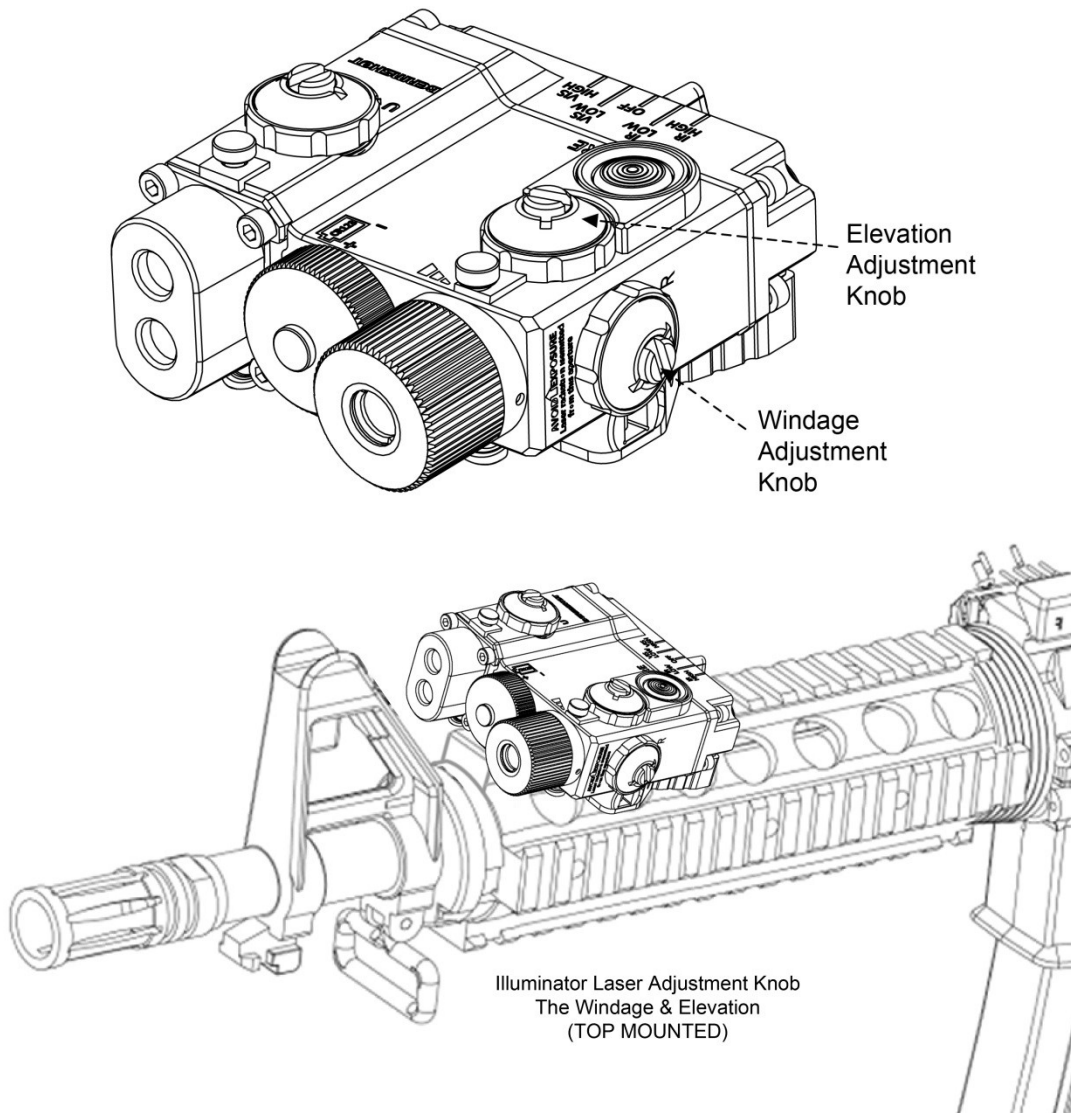

Beam Movement for the IR Laser Illuminator (Top Mounted)

Note

Do not over torque the adjustment knobs beyond the stop.
Caution must be taken to only adjust them **“finger-tight”**

Windage & Elevation Adjustment Knobs

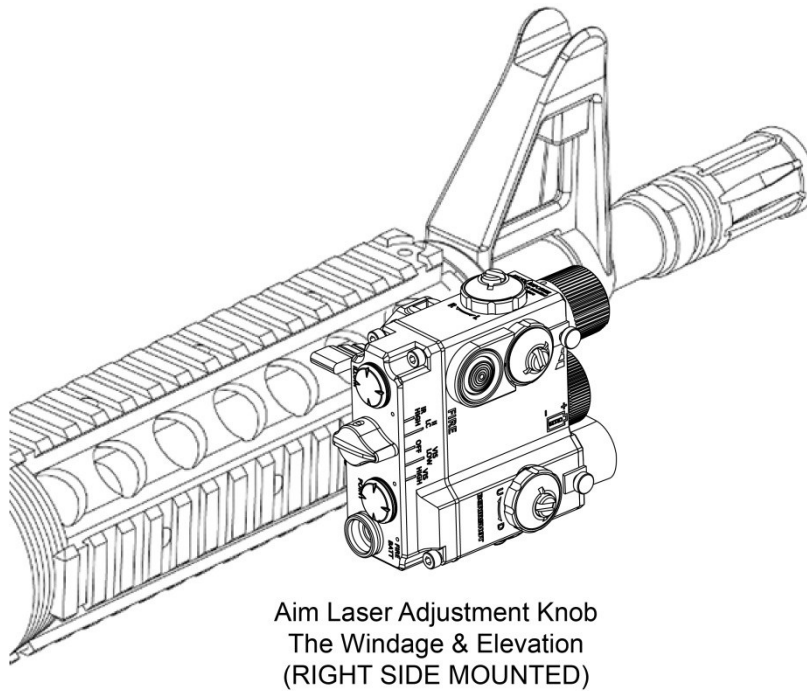
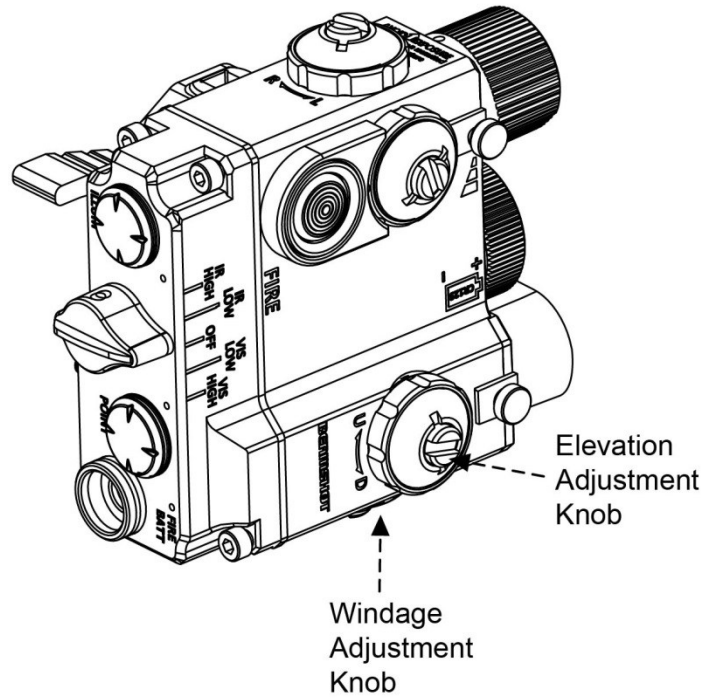

Shot Group Movement for Laser Point (Right Side Mounted).

NOTE

Do not over torque the adjustment knobs beyond the stop.
Caution must be taken to only adjust them "finger-tight".

Windage & Elevation Adjustment Knobs

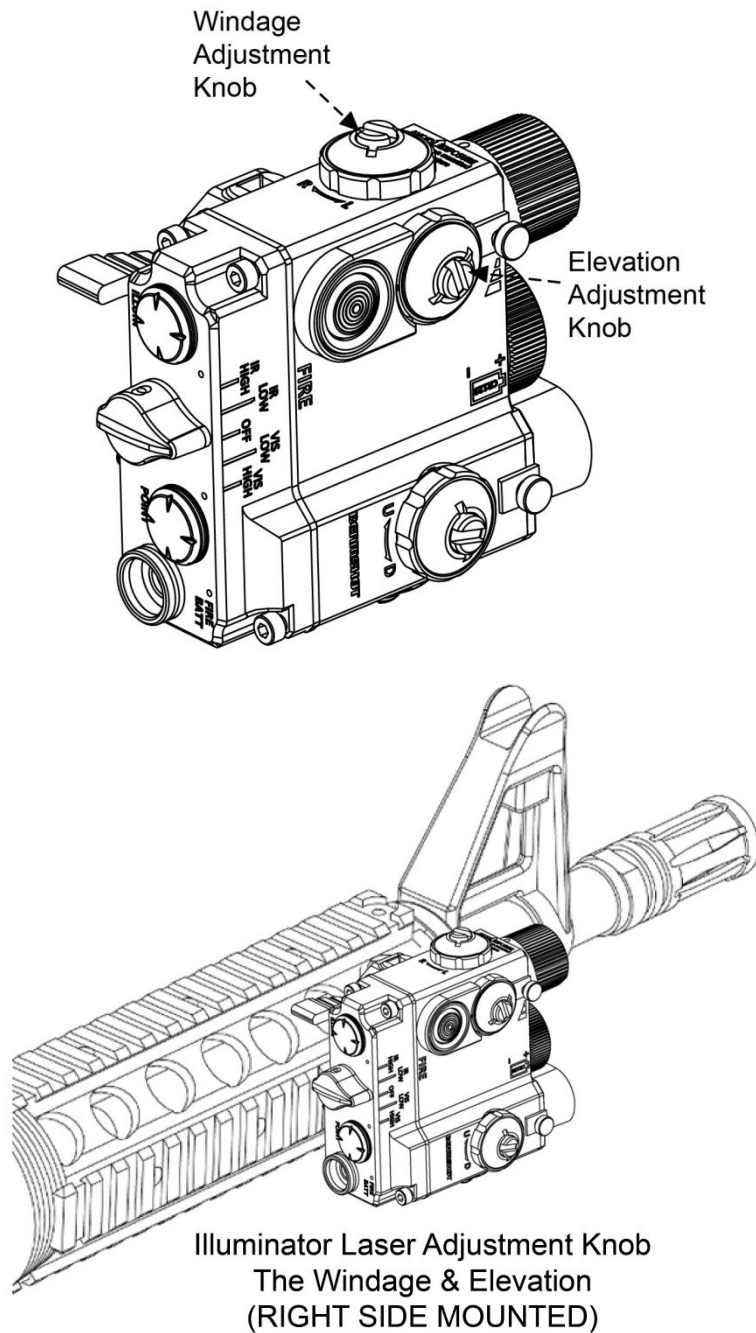

Beam Movement for the IR Laser Illuminator
(Right Side Mounted).

NOTE

Do not over torque the adjustment knobs beyond the stop.
Caution must be taken to only adjust them "finger-tight".

Windage & Elevation Adjustment Knobs

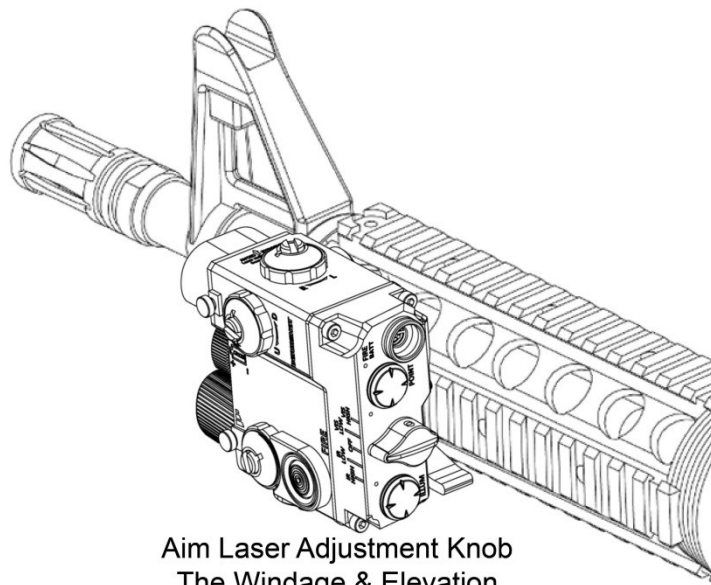
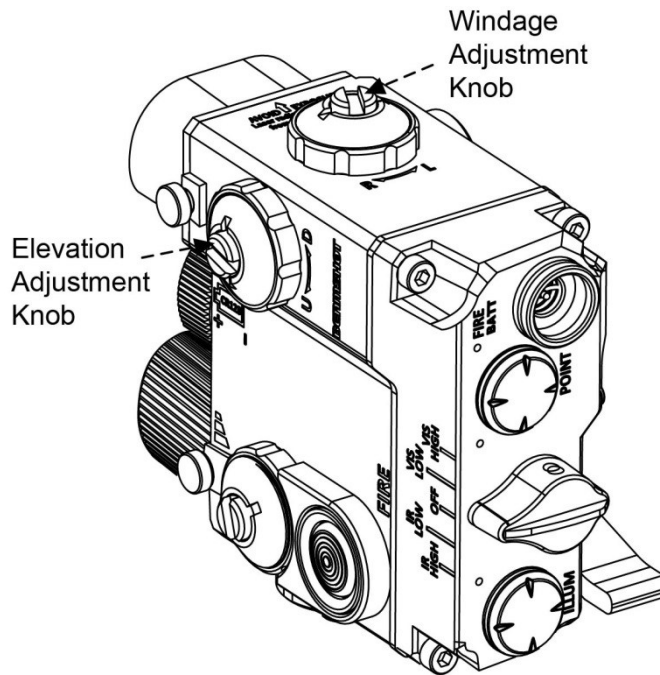

Shot Group Movement for Laser Point (Left Side Mounted).

NOTE

Do not over torque the adjustment knobs beyond the stop.
Caution must be taken to only adjust them "finger-tight".

Windage & Elevation Adjustment Knobs

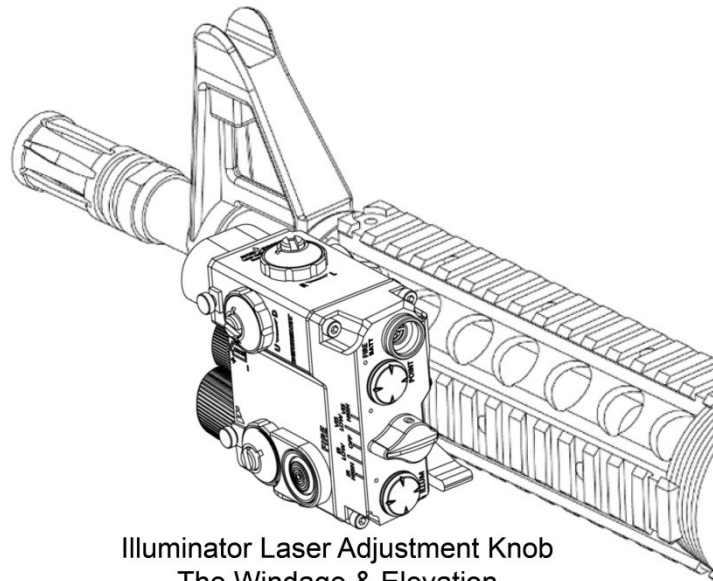
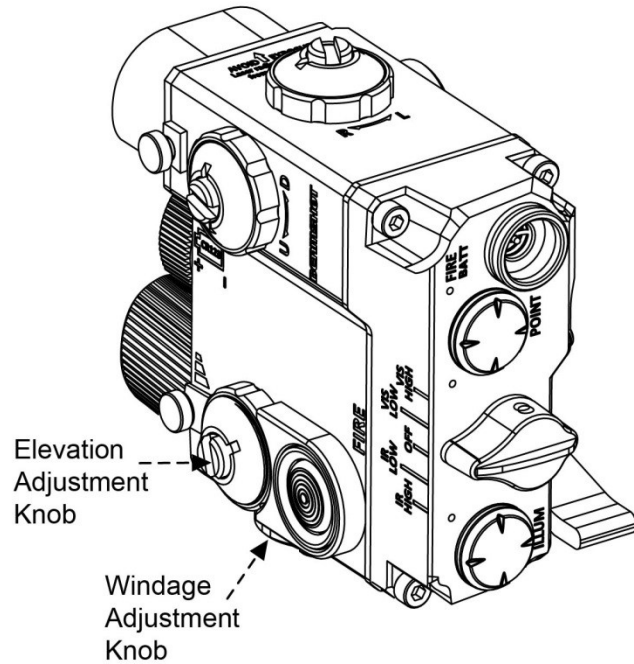

Illuminator Laser Adjustment Knob
The Windage & Elevation
(LEFT SIDE MOUNTED)

Beam Movement for the IR Laser Illuminator
(Left Side Mounted).

NOTE

Do not over torque the adjustment knobs beyond the stop.
Caution must be taken to only adjust them "**finger-tight**".

CHAPTER 5

BASIC MAINTENANCE

1. Make sure the Power Selector Knob is on **Power OFF** position.
2. **Keep all of the rubber Safety Covers closed.** Rinse the housing with water and wipe dry, clean with a soft cloth.
3. Remove the battery and close the battery cap.
4. Open the rubber safety covers. Rinse the Laser-emitting and Infrared Laser Illuminator Apertures with water and wipe clean with a dry lens cleaning tissue. Brush off all loose dirt from the apertures carefully.
5. Clean around fire buttons, power selector knob, function switch, adjustments ...etc with a soft cloth or disposable applicator.
6. Wipe dust and dirt from all components with a soft dry cloth.
7. Make sure the Power Selector Knob is on **Power OFF** position again.

CAUTION

- When not in use, Always keep the Power Selector Knob on POWER OFF position, Including when in storage.
- When not in use, Always close all of the Rubber Safety Covers, Including when in storage.
- Do not allow water to enter the housing by keeping the battery cap shut.
- Do not store the LAS31 with battery installed.

APPENDIX

REPAIR PARTS LIST & SPECIAL TOOLS

Items	Parts Stock Number (PSN)	Description	Qty/SYSTEM
1	451-C0103G	CR123A Battery	1
2	492-5B101G	Hard Covered Carrying Case	1
3	264-5B111G	MPSR-10 : 10 inches long Magnetic connection Pressure pad Switch	1
4	264-5B112G	MPSV-10 : 10 inches long Magnetic connection Pressure pad Switch with Velcro attached	1
5	467-07005G	Polyester elastic band	1
6	467-07001G	Velcro Pad	2
7	499-5B110G	Lens cloth	1
8	494-50705G	User Manual	1
9	476-5B110G-2	Battery cap rubber strap	1
10	476-BQ003G	Laser point safety cover	1
11	476-5B103G-5	IR laser illuminator safety cover	1
12	426-5BF01G-3	Alignment Plate	1
13	257-BQ010G	Battery cap	1
14	461-15005G	Battery cap – Orange O-Ring	1
15	461-14001G	Battery cap – Black O-Ring	1

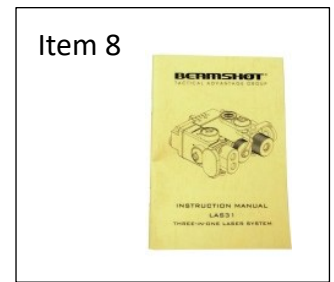

Item 9



Item 10



Item 11



Item 12



Item 13



Item 14



Item 15



BEAMSHOT is the weapons sighting division of Quarton USA Inc. Under the trademark name of BEAMSHOT we manufacture some of the finest and most innovative laser sighting systems in the world. We manufacture laser sights for pistols, rifles, shotguns and bows. We also manufacture Tactical LED flashlights, “LAS41P” four in one laser system and “LLC-Compact” laser light combo system. For more product information, please visit **beamshot.shop**.

This manual contains technical data whose export is governed by QUARTON USA Inc.

Don't hesitate to contact us if you have any questions or concerns. We welcome all inquiries.

The LAS31

is designed and produced by: QUARTON USA Inc.

www.beamshot.com

E-mail : beamshot@quarton.com

©2026 Quarton USA Inc.